

MODEL 65023

SHEAR BEAM LOAD CELL

APPLICATIONS

- Floor scales
- Tank weighing
- Bin and hopper weighing

FEATURES

- Rated capacities 500 to 20,000 pounds;
250 kilograms to 10 metric tons
- Stainless steel versions available
- "Thru" or "threaded" load hole configurations
- Low sensitivity to axial loads
- 65059 TWA companion weighing assemblies available
- 65082 Tantamount companion weigh modules available
- Low profile (ultra low available in 1,000 to 2,500 pound ranges)
- Trade certified for NTEP Class III L:10,000 divisions;
Class III:5,000 divisions and OIML R60 3,000 in
1,000 to 10,000 pounds
- **Sensorgage™** sealed to IP67 standards
- **Cell Guard™** Two Year Warranty includes moisture protection
- Factory Mutual System Approved for Classes I, II, III;
Divisions 1 and 2; Groups A through G.
Also, **Non-Incendive** ratings (No Barriers!)
- ISO 9001 Certified manufacturing facilities

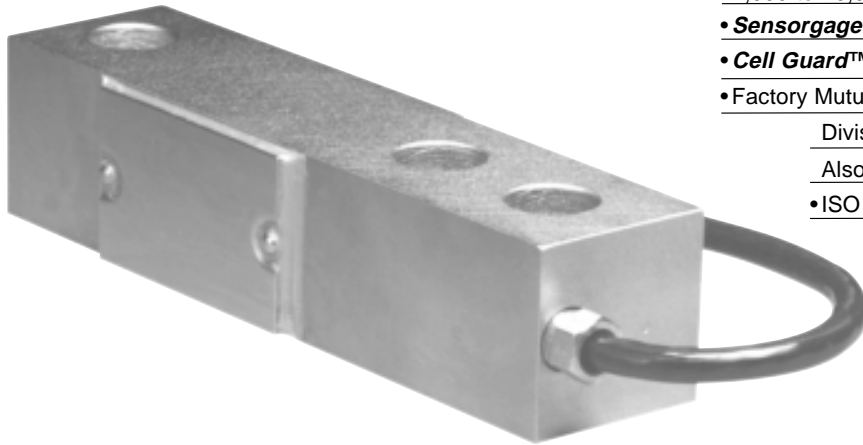

65059-TWA



65082-TWA



Model 65023 Performance Specifications

Rated Capacities (lbs): 500, 1K, 1.5K, 2K, 2.5K, 4K, 5K, 10K, 15K, 20K

(kgs/metric tons): 250kg, 500kg, 750kg, 1t, 2t, 5t, 10t

Full Scale Output (FSO): 3.0 mV/V \pm 0.25%

Accuracy Class:	Standard	NTEP III ⁽¹⁾	NTEP IIII ⁽¹⁾	OIML R60 ⁽¹⁾
Max. No. Verification Intervals	--	5,000 Multiple	10,000 Multiple	3,000
Combined Error % FSO	$\leq .03$	--	--	--
Non-Linearity % FSO	$\leq .03$	--	--	--
Hysteresis % FSO	$\leq .02$	--	--	--
Creep Error % FSO	$\leq .03$ in 20 minutes	--	--	--
Temperature Effect on:				
• Zero % FSO/°F	≤ 0.0015	--	--	--
• Output % of Load/°F	≤ 0.0008	--	--	--
Non-Repeatability % FSO		$\leq .01$		
Zero Balance % FSO		≤ 1.0		
Insulation Resistance		> 1000 Mohms at 50 VDC		
Compensated Temperature Range		14° to 104°F / -10° to 40°C		
Operating Temperature Range		0° to 150°F / -18° to 65°C		
Storage Temperature Range		-60° to 185°F / -50° to 85°C		
Input Resistance		343-357 Ohms		
Output Resistance		349-355 Ohms		
Recommended Excitation Voltage		10 Volts DC		
Maximum Excitation Voltage		15 Volts DC		
Sideload Rejection Ratio		500:1		
Safe Sideload		100% of Rated Capacity		
Safe Overload		150% of Rated Capacity		
Ultimate Overload		300% of Rated Capacity		
Sealing		Meets IP67 Standards		
Material		Alloy Tool Steel		
Finish		Electroless Nickel		

⁽¹⁾ Note: 1K - 10K capacities only.

4 CONDUCTOR CABLE; 22 AWG.,
SHIELDED & JACKETED;
20 FOOT STANDARD LENGTH
OR PER SALES ORDER.

WIRING

FUNCTION	COLOR
+ Excitation	Red
- Excitation	Black
+ Output	Green
- Output	White

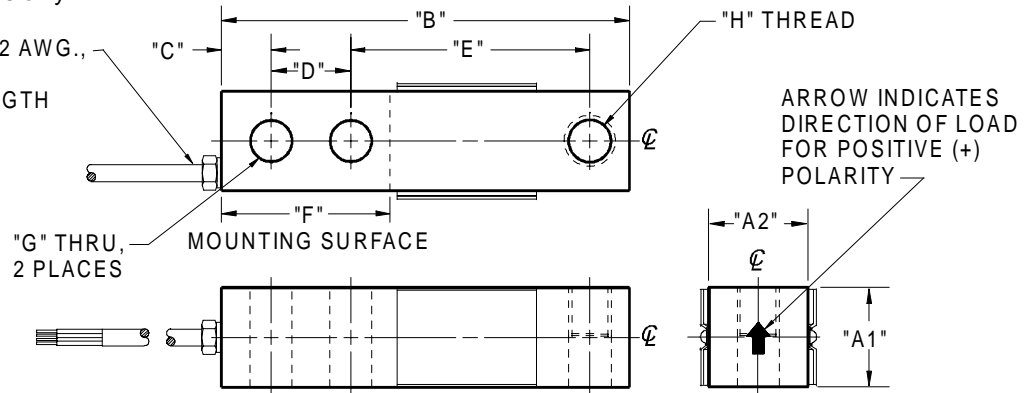

CAPACITY	A1	A2	B	C	D	E	F	G	H	Deflection	Weight
500 lbs	1.00	1.25	5.12	0.62	1.00	3.00	2.25	0.53	1/2-20 UNF-2B, Ø0.53 x 0.50 DEEP C'BORE	0.013	1.7
1K - 4K	1.25	1.25	5.12	0.62	1.00	3.00	2.25	0.53	1/2-20 UNF-2B, Ø0.53 x 0.62 DEEP C'BORE	0.017 - 0.025	4.0
5K - 10K	1.50	1.50	6.75	0.75	1.50	3.75	3.00	0.78	3/4-16 UNF-2B, Ø0.78 x 0.75 DEEP C'BORE	0.025 - 0.035	6.5
15K - 20K	2.00	2.00	8.88	1.00	2.00	4.88	4.00	1.03	1"-14 UNF-2B, Ø1.03 x 1.00 DEEP C'BORE	0.048 - 0.063	9.0
(250kg)	(25.0)	(31.0)	(130.0)	(16.0)	(25.0)	(76.0)	(57.0)	(13.0)	M12 x 1.75-6H, Ø13 x 15 DEEP C'BORE	(0.33)	(0.8)
(500- 2t)	(32.0)	(32.0)	(130.0)	(16.0)	(25.0)	(76.0)	(57.0)	(13.0)	M12 x 1.75-6H, Ø13 x 15 DEEP C'BORE	(0.432 - 0.635)	(1.8)
(3t - 5t)	(38.0)	(38.0)	(171.0)	(19.0)	(38.0)	(95.0)	(76.0)	(20.7)	M20 x 2.5-6H, Ø20.5 x 19 DEEP C'BORE	(0.635 - 0.889)	(2.9)
(10t)	(51.0)	(51.0)	(226.0)	(25.0)	(51.0)	(124.0)	(102.0)	(25.0)	M24 x 2-6H, Ø25.4 x 25 DEEP C'BORE	(1.219 - 1.600)	(4.1)

Dimensions are in inches (millimeters). Capacities are in pounds (kgs/metric tons). Deflection is \pm 10%. Specifications are subject to change. Certified drawings are available.

